



C4012B

for up to 12S LiPo & LiFe & LiTo

3mV voltage accuracy
1500W charge power at AC
500W charge power at DC
1.2A balance current
2.8" TFT LCD display



Thanks for your purchasing the 1500W CHARGER for your e-Vehicle or RC model.

Read the ENTIRE instruction manual to become familiar with the features/functions of the device before operating.

Feel free to send an email to jasonwang3a@163.com or call at 86 755 2643 6165 should you have any questions and suggestions.

Jason Wang



Chargery C4012B charger uses advanced Synchronous buck-boost DC/DC converter technology, high power, high current and high-performance power conversion circuit. The maximum charge power up to 40A 1500W at AC input, and 20A 500W at DC input, the maximum charge/discharge current is up to 40A. The charger can charge up to 12S LiPo, Lilo, LiTo, LiFe, with maximum 1.2A balance current, adopts unique balance circuit resume all cells voltage as fast as possible.

Safety Notes

Please read the manual completely before using, to make sure you can use this device better and more safely.

1. Keep the charger away from children and pets at all times.
2. Never leave the charger unsupervised when charging or discharging. If you leave, disconnect the battery to prevent any unexpected dangers or damage.
3. Ensure the charger program and settings match the battery pack otherwise the battery will be damaged and a dangerous situation may arise, especially for Lithium batteries which may cause a fire.
4. Don't cover the cooling fan.
5. Do not mix batteries of different types, different capacities or from different manufacturers.
6. Never charge or discharge any battery having evidence of leaking, expansion/swelling, damaged outer cover or case, color-change or distortion.
7. Do not place the charger or any battery on a flammable surface or near a combustible material while in use. Do not charge or discharge on a carpet, cluttered workbench, paper, plastic, vinyl, leather or wood, inside an R/C model or inside a full-sized automobile.
8. Do not try to charge "non-rechargeable" dry cells.
9. Never block the air intake holes and Don't use the charger in a refrigerated or high temperature environment.
10. Do not allow water, moisture, metal wires or other conductive material into the charger.
11. Do not exceed the battery manufacturer's suggested maximum charge and discharge rates.
12. Carefully follow the battery pack manufacturer's recommendations and safety advice.

Copyright

Copyright@Chargery Power Co., Ltd. All rights reserved.

Without prior written consent by Shenzhen Chargery Power Co., Ltd, any units or individual extract and copy parts or entire contents of this manual, and transmission in any form is illegal and strictly prohibited.

The product described in this manual, may include copyright software ownership belonged to Shenzhen Chargery Power Co., Ltd and its licensee, except getting the permission from relevant rights holders, otherwise any copy, distribute, modify, excerpt, decompile, disassemble, decrypt, reverse engineering, lease, transfer, sub-license, as well as other acts of infringement of software copyright is strictly prohibited, but apart from the restrictions prohibited by applicable law.



Special Features

1. Unique charge architecture realized better transient response to any changes of voltage on input and output.
2. The charger use advanced ADC measurement technology, high accuracy, high voltage and high current detection circuit. The maximum voltage measurements tolerance is within 5mV at up to 12S LiPo battery.
3. The charger adopts advance balance circuit and Algorithm, constant 1.2A per cell balance current is very useful for large capacity battery pack, the feature can resume all cell voltage balance status at the shortest time. Over temperature protection make sure the system safety during balance.
4. Maximal 100W discharge power need not any external load, Over temperature protection make sure the system safety during discharge.
5. Charger internal temperature protection. When the internal temperature exceeds the setup temperature, the output power is automatically decreased; and the charger will stop working when temperature exceeds the shut-down temperature.
6. Intelligent fan control circuit sense internal temperature via temperature sensor, to thereby control the fan speed.
7. TFT LCD screen provides rich information including current, voltage, power, capacity, time, working status and temperature and so on.
8. The charger features a maximal safety protection,
 - Reversed polarity protection on input and output
 - Anti-spark on input and output even connect to 50V battery.
 - Wrong battery connection protection when multi battery pack connected in series on adapter board.
 - Charge time, charge capacity and battery temperature protection.
9. Supports upgrading the firmware program by USB port.

Specifications

1. Input voltage: DC 10-38V, 38V max. or AC 100-265V.
2. Input Current: 25A maximal at DC input, and 15Arms at AC110V input
3. Charge current: 0.1-20A, 500W max. at DC input, or 1-40A, 1500W max. at AC input
4. Discharge Current: 0.1-40A, 100W max.
5. Accuracy of the cell voltage: -5mV/+5mV
6. Balance current: 1.2A per cell only for LiPoly, Li-ion, LiTo and LiFePO4 battery pack
7. Battery Type: LiPoly, Li-ion, LiHV, LiTo, LiFePO4, NiMh/NiCd, Pb acid(VRLA) battery pack

	C4012B
LiPo/LiHV battery ¹⁾	1-12S
LiTo battery	1-12S
LiFePO4 battery	1-12S
NiMH/NiCd battery ²⁾	1-35S
Pb battery—Lead Acid or AGM battery	1-21S (42V)

- 1) The terminal voltage per cell can be set up to 4.40V only for High Voltage LiPo battery. Li-ion, NMC(LiNiMnCoO2) battery is also be supported.
- 2) NiMh/NiCd cell count is identified automatically



Mechanical Characteristics

- Size: 281*170*68 (L×W×H, mm) or 11.1×6.69×2.68 (L×W×H, inch)
- Weight: 3.5Kg without any accessories.
- Input power cable: AWG14 wire, 600mm length for DC; AWG14 wire 1.5m length for AC
- Output DC connector: XT-90 male connector

Packaging Content

- Charger unit: 1pcs
- Power cable for DC: 1pcs, AWG14 wire, 600mm length with 4mm gold male connector
- Power cable for AC: 1pcs, AWG14 wire, 1500mm length
- USB data line: 1pcs
- Temperature sense lead: 1pcs
- adapter wire: 2pcs, connect charger to adapter board
- adapter board:2pcs
- XT-90 female conntor:1pcs

Interface

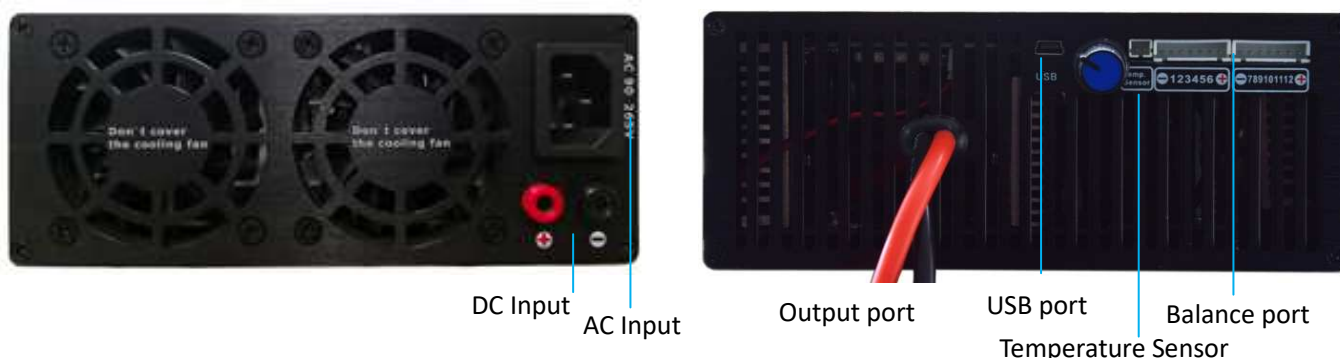

DC Input	Connect to power supply or battery, DC voltage range is 10V to 28V, absolutely 30V maximal
AC Input	Connect to AC source 90-265V 50/60Hz
USB port	Connect to PC update the firmware by Chargery UpdateTool.
Output port	Connect to battery.
Temperature sensor port	Connect to temperature sensor monitor battery temperature, the sensor must be pasted tightly battery during charge or discharge. battery temperature can affect battery life and performance seriously, the maximal temperature should not be over 40 °C during charge.
Balance port	Connect to adapter board or battery directly for Balance charge or Balance only.
STOP/SET	When the charger operate any program, Press STOP button terminate it. In main interface, and no any program operate, Press for 2 seconds get the cell and battery impedance.
Knob	Decrease parameter value or alternate menu item by rotate the Knob clockwise Increase parameter value or alternate menu item by rotate the Knob counterclockwise
Knob	In main interface, press Knob for 3 seconds, the unit will enter into function interface directly, press for 3 seconds will operate last program directly. In Battery Type interface, press for 3 seconds, the unit will enter into charger setting menu. In Memory Select interface, press for 3 seconds, the unit can edit memory name In function interface, press for 3 seconds, the unit will operate chosen program.

Program Setting

1. On Battery Type interface, Press **Knob** button for 3 seconds enter into CHARGER SETTING interface.
2. Rotate **Knob** button select the item, press **Knob** shortly make the value flash, and rotate change the value. Press **knob** button shortly confirm the change. After finish all setup, press **knob** for 3 seconds quit the setup menu.
3. When quit setup mode, the charger will save all parameters till next change.



NOTE: Please keep the default setup unless for special purpose.

Parameters	Min.	Default	Max.	Step	unit
Temperature Unit		Celsius	Fahrenheit		
Fan ON, Fan start temperature	35	40	50	1	°C
Shut Down, the charger stop working when internal heat sink temperature reach the value	50	70	100	1	°C
Battery Temp. Cut	25	40	80	1	°C
Maximal Capacity, maximal charged capacity	10	120	200	1	%
Safety Timer, maximal charged time ⁽¹⁾	1	120	9999	1	min
Key Beeper		ON	OFF		
Alarm Tone	5	10	20	1	second
Done Tone ⁽²⁾					
LCD Back-Light Time ⁽³⁾	1	10	255	1	min
DC Charge power	10	500	500	1	W
Discharge power	5	100	100	1	W
Cell Voltage Calibration ⁽⁴⁾					

NOTES:

- 1) If alternate choose OFF, the safety timer will be inactive.
- 2) Done tone sound have 4 mode: 30seconds, 3 min, 5times and always. Press Knob or **STOP/SET** turn off the sound.
- 3) Always will make the LCD Back-Light is ON till power off the charger
- 4) **Cell Voltage Calibration** is not recommended, all voltage and current is calibrated before delivery. when need calibrate cell voltage, In Battery Type interface, please press **Knob** Button for 3 seconds enter into CHARGER SETTING interface, rotate **Knob** button select Cell Voltage Calibration and press **Knob** button shortly enter into calibration interface as following picture.

- a) Choose Cell Voltage Calibration and press **Knob** button shortly, you will find cells voltage, press **Knob** and rotate modify voltage according to standard voltage, choose NEXT and press **Knob** button for 3 seconds save data.



- b) Choose Default Cell Voltage and press **Knob** shortly resume all cell voltage to default value.
- c) Press **Knob** for 3 seconds return previous interface.

Operating guideline

1. Connect the charger to power supply or battery pack with 10-28V, the unit will start and display Chargery logo, model, version and series number, 2 seconds later, main interface is displayed. as following picture.

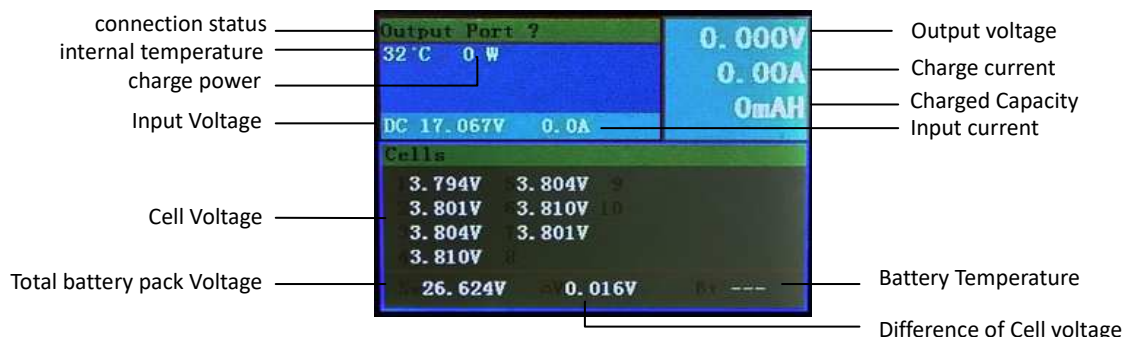

The charger can identify DC or AC source connection.

2. Press **STOP/SET** for 2 seconds get the cell and battery impedance.

Warning: for 2 or 3 batteries connected in series, please check the details on page 11 before next step operation, wrong connection will burn adapter board even short circuit the battery.

3. Connect battery positive and negative to charger output.
4. Connect to battery on Balance port
5. Press **Knob** shortly enter into battery type as right picture, rotate **Knob** alternate battery type. Press **STOP/SET** return last interface.
6. Press **Knob** shortly on any battery type display Memory Selection interface. As below right picture. Press **STOP/SET** return last interface.
7. Press **Knob** shortly on any memory name enter into function selection interface. Take LiPo battery as sample. each battery memory record all parameters include cell count, charge current, end voltage and so on, the charger is built in one memory including a set of default value before delivery, the default memory name is LiIo, LiPo, LiFe, NiMH, NiCd or Pb.

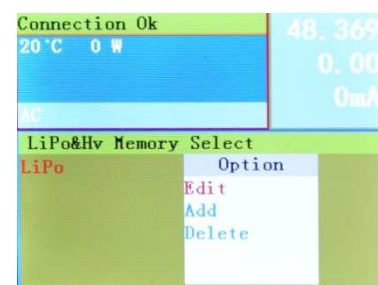
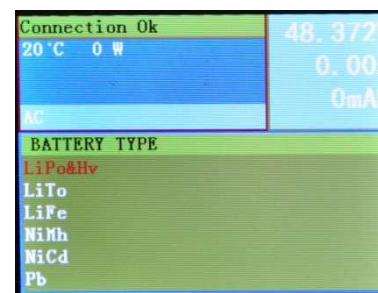
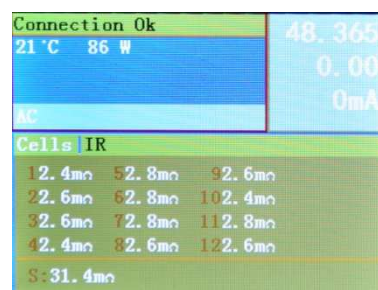

Press **Knob** button for 3 seconds Edit, Add or Delete recorded memory data as right picture. one memory data has a memory name and include a set of charge and discharge parameters, you can save a set of parameters for your each battery, the charger can save up to 10 set of parameters for each battery type.

Rotate **Knob** alternate Edit, Add or Delete, Press Edit and rotate **Knob** modify saved memory name. Press Delete delete saved memory data. Press Add save new data.

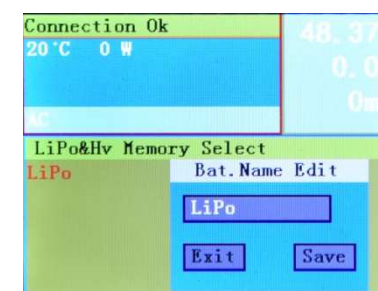

if need add new data record, first press Add and rotate **Knob** rename a memory name (press STOP/SET back to last name), then press Save and save it. After you choose new memory name and modify some parameters, the charger will record the latest parameters. Press Exit don't save any change. see right picture.



8. Press **Knob** shortly on any function, the function parameters setup interface will be displayed, Press **Knob** choose item and rotate **Knob** modify. For all lithium battery, there are Charge, Balance Charge, Discharge, Storage, Cycle and Balance functions. Take as LiPo Charge as sample. The details are as below pictures.

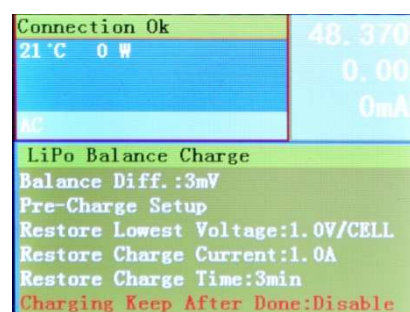
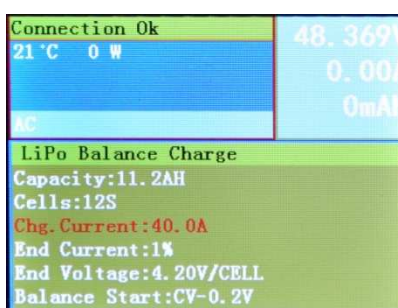
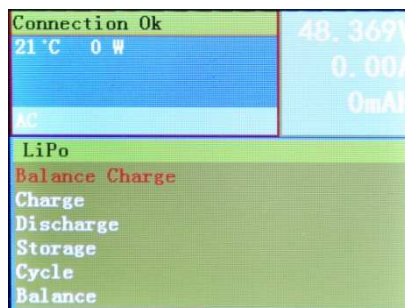

The details of parameters set up for **LiPo&HV, LiTo and LiFe** battery is in the following table.

Parameters	Min.	Default	Max.	Step	unit	
Charge						
Capacity---Rated battery capacity ¹⁾	0.1	3	100	0.1	Ah	
Cells-----cell count ²⁾	C4012B	1	3	12	1	
Chg. Current----Charge current	DC input	0.1	5	20	0.1	A
	AC input	1	5	40	0.1	A
End Current----Charge terminal current	5	10	20	1	%	
End Voltage----Charge terminal voltage per cell	LiPo&Hv ³⁾	3.85	4.20	4.40	0.01	V
	LiTo	1.50	2.75	2.80	0.01	V
	LiFe	3.20	3.65	3.65	0.01	V
Pre-charge Setup						
Restore Lowest Voltage per cell---any cell voltage cannot be charged to over setup, the charge will stop	0.5	1.0	2.5	0.1	V	
Restore Charge Current	0.1	0.5	1	0.1	A	
Restore Charge Time	1	3	5	1	min	
Balance charge						
Balance Start---any cell voltage reach the value, balance function will start ⁴⁾	CV-0.0	CV-0.2	CV-1.0	0.1	V	
Balance Diff--- balance stop when difference of cell voltage less than or equal to the value	3	5	10	1	mV	
Discharge						
Dchg. Current---discharge current	0.1	2.0	40	0.1	A	
End Current---Discharge terminal current	1	50	100	1	%	
End Voltage--- Discharge terminal voltage per cell	LiPo&Hv ³⁾	2.50	3.00	4.10	0.01	V
	LiTo	1.50	2.00	2.50	0.01	V
	LiFe	2.00	2.50	3.40	0.01	V
Storage						
Sto. Voltage---Storage voltage per cell ⁵⁾	LiPo&Hv ³⁾	3.65	3.85	3.90	0.01	V
	LiTo	2.00	2.30	2.50	0.01	V
	LiFe	3.10	3.20	3.30	0.01	V
Cycle						
Cycle Mode	CHG--->DCHG		DCHG--->CHG			
Cycle Count	1	3	99	1		
Delay Time---the time between charge and discharge	0	3	999	1	min	
Balance						
Balance Diff.	3	5	10	1	mV	



- 1) **Ignore** means the charged capacity cannot be as control condition.
- 2) **Auto** means the charger will identify cell count automatically
- 3) Charge and discharge terminal voltage is most important, if cannot confirm battery chemistry, please read battery datasheet, and then setup the voltage per cell according to battery datasheet.

With the large demands of new energy car and storage system, many new battery chemistry system is in developing, more and more new battery positive material is applied to new lithium battery, now the popular lithium battery is NMC(LiNiMnCoO₂) in China, So before charge any lithium battery, please must read battery or cell datasheet seriously, whatever any new chemistry or positive material, charge terminal voltage and maximal charge current must be described.

- 4) **Always** means the charger start to balance when start to charge. CV is charge terminal voltage per cell.
- 5) On Storage mode, the program will charge or discharge battery pack to storage voltage, the charge and discharge current will be as same as Charge and discharge mode.

For **NiMH/NiCd** battery, there are Charge, Discharge and Cycle functions. As below pictures.

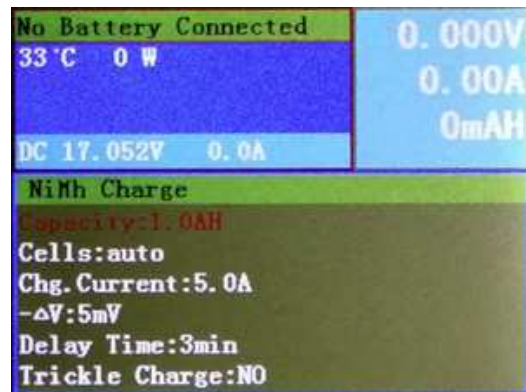
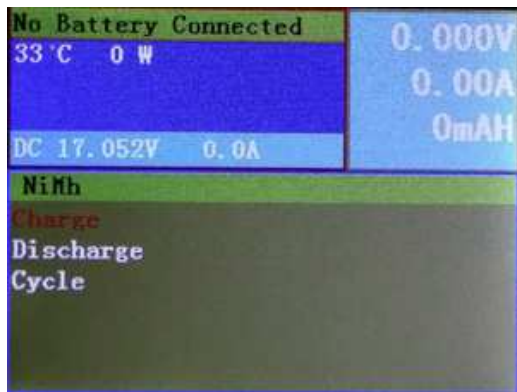

The Details of parameters set up for **NiMH/NiCd** battery is in the following table.

Parameters	Min.	Default	Max.	Step	unit	
Charge						
Capacity---Rated battery capacity ¹⁾	0.1	3	100	0.1	Ah	
Cells-----cell count	C4012B	Auto				
Chg. Current----Charge current	DC input	0.1	5	20	0.1	A
	AC input	1	5	40	0.1	A
-ΔV	5	5	20	1	Mv	
Delay Time---Battery Voltage restore time	0	3	20	1	min	
Trickle Charge		NO	YES			
Trickle Current	0.1	0.5	1	0.1	A	
Trickle Time	1	5	999		min	
Charge Mode		Normal				
Discharge						
Dchg. Current---discharge current	0.1	2.0	40	0.1	A	
End Current---Discharge terminal current	1	50	100	1	%	
End Voltage--- Discharge terminal voltage	C4012B	0.7	0.7	20	0.01	V
Cycle						
Cycle Mode	CHG→DCHG		DCHG→CHG			
Cycle Count	1	3	99	1		
Delay Time---the time between charge and discharge	0	3	999	1	min	

1) **Ignore** means the charged capacity cannot be as control condition.

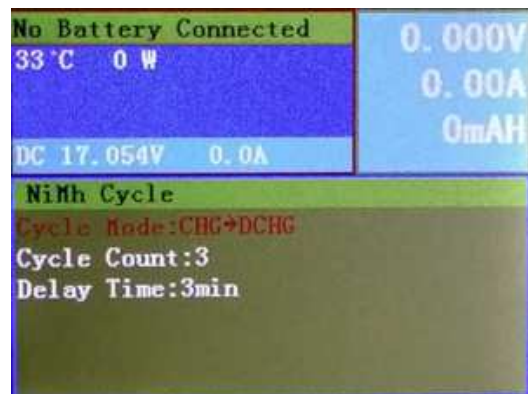



For **Pb acid battery (VRLA)** battery, there are Charge, Discharge and Cycle functions. As below pictures.

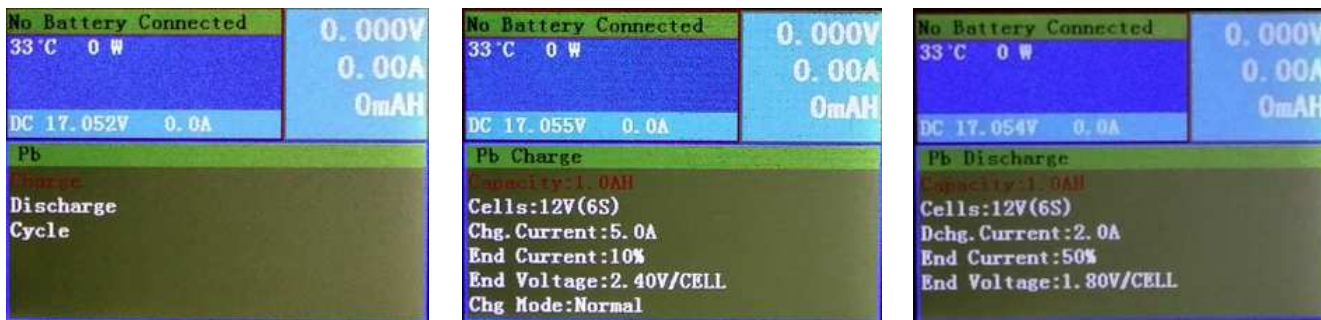

The details of parameters set up for **Pb acid battery (VRLA)** is in the following table.

Parameters		Min.	Default	Max.	Step	unit	
Charge							
Capacity---Rated battery capacity ¹⁾		0.1	3	100	0.1	Ah	
Cells-----cell count		C4012B	1	6S(12V)	21		
Chg. Current---Charge current		DC input	0.1	5	20	0.1	A
		AC input	1	5	40	0.1	A
End Current---Charge terminal current		1	10	50	1	%	
End Voltage---Charge terminal voltage per cell		2.00	2.40	2.50	0.01	V	
Charge Mode			Normal				
Pre-charge Setup							
Restore Lowest Voltage per cell---any cell voltage cannot be charged to over setup, the charge will stop		0.5	1.0	2.5	0.1	V	
Restore Charge Current		0.1	0.5	1	0.1	A	
Restore Charge Time		1	3	5	1	min	
Discharge							
Dchg. Current---discharge current		0.1	2.0	40	0.1	A	
End Current---Discharge terminal current		1	50	100	1	%	
End Voltage--- Discharge terminal voltage per cell		1.50	1.80	2.40	0.01	V	
Cycle							
Cycle Mode		CHG-→DCHG		DCHG-→CHG			
Cycle Count		1	3	99	1		
Delay Time---the time between charge and discharge		0	3	999	1	min	

1) **Ignore** means the charged capacity cannot be as control condition.

9. Finish all parameters setup, press **Knob** for 3 seconds, pop up a window, press YES start to operate program.
10. Press **STOP/SET** stop any program and return to program operating interface.



As power supply

When connect the charger to AC source, on Battery type interface, choose power supply setup output voltage and maximal output current, the charger will work as a programmed power supply; you can set up the output voltage and maximal output current, and then press **Knob** for 3 seconds power on the charger.

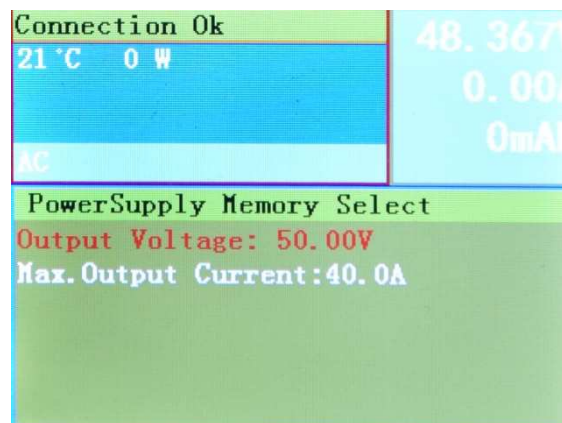

- Output voltage adjustment range: 5V~50V,
- Output current adjustment range: 5A~40A.

Error or Warning

When any mistakes triggered, the charger will stop working, and display error information, press **Knob** return main interface.

Such as if the battery connection bread down, the battery connection error will be displayed on the top line. If the battery temperature over the setup value, "Over Temperature" will be displayed, as so on.

Tips

1. In main interface, press for 3 seconds, the charger will enter into function interface directly, press for 3 seconds will operate last program directly.

2. During charge in CC phase, the charge current can be set up to new value and need not stop charging. On Cells and Info page, press **Knob** button for 3 seconds, Ch. Current modification window is pop up, please press **Knob** and rotate **Knob** button modify charge current, press **Esc** quit and press **Ok** save the change. The charger will charge at new current.

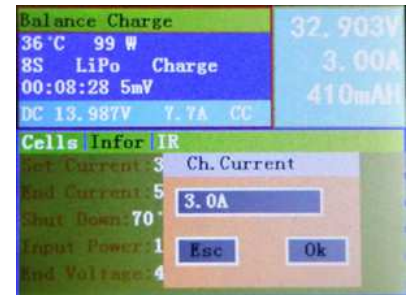

And rotate **Knob** to alternate Cells, Info and IR label page, on Info page, you will check some preset parameters and actual input power.

Original Charge current
charge terminal current
Shut down Temperature
Input power
Charge terminal voltage/cell

On IR page, you can check each cell impedance and total battery

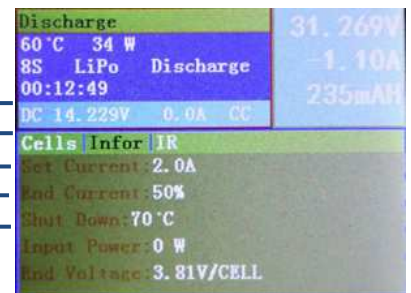

impedance

3. During discharge, the discharge terminal voltage can be changed and need not stop discharging, On Cells and Info page, press **Knob** button for 3 seconds, Disch. End.Voltage modification window is pop up, please press **Knob** and rotate **Knob** button modify end voltage per cell, press **Esc** quit and press **Ok** save the change. The charger will continue to discharge and stop at new terminal voltage.

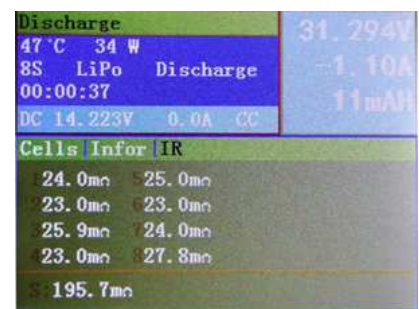
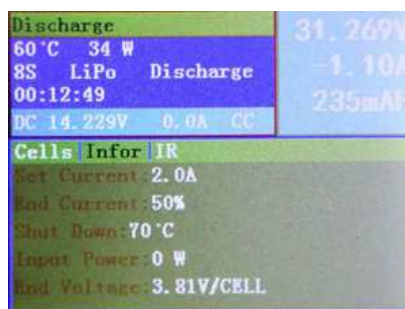
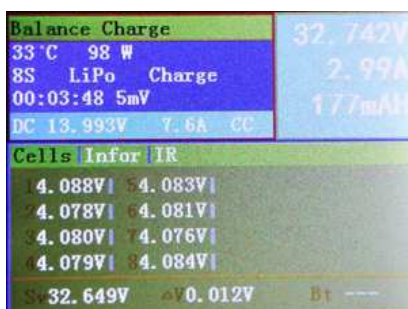
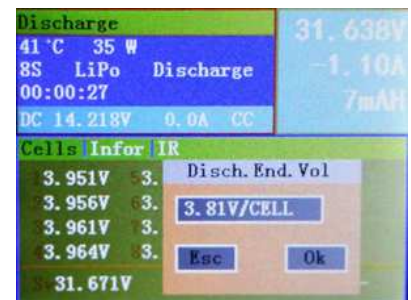

4. On LiTo, LiPo&Hv and LiFe battery balance charge program, Enable "Charging Keep After Done", continue to charge at smaller current when charging is done. Disable the function, will stop really charging.

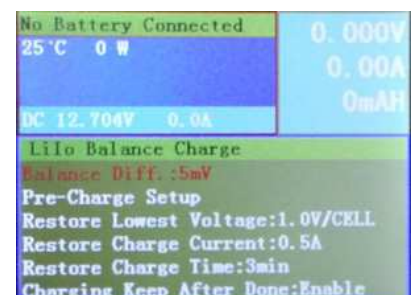

Firmware Upgrades via USB Port

1. Go to <http://www.chargery.com/uploadFiles/ChargeryupdateTool.zip> to download the ChargeryupdateTool.zip, the zip file include Chargery USB driver, and Chargery Update Tool, extract to any disk on the PC.
2. To install the USB driver, run the program X:\ChargeryupdateTool\ChargeryUSBdriver.exe (where X is the drive letter designator for your CD-ROM drive.)
3. In the same directory, double click to run the update tool and enter program interface.
4. Connect the charger to the PC by the USB data cable. When the port number (such as com5) appears, this shows the update tool identified the charge. Click OPEN button lock the port please.
5. Click Open file button open the firmware file. If there is no firmware file on the PC, you can download the file on <http://www.chargery.com/uploadFiles/firmwareFiles/> to your PC.
6. Click the Update button, then the update progress bar will appear on the bottom, update complete will be displayed on PC. The charger display the progress bar simultaneously and restart the charger after finish update.



Maximal Charge Power VS DC Input Voltage

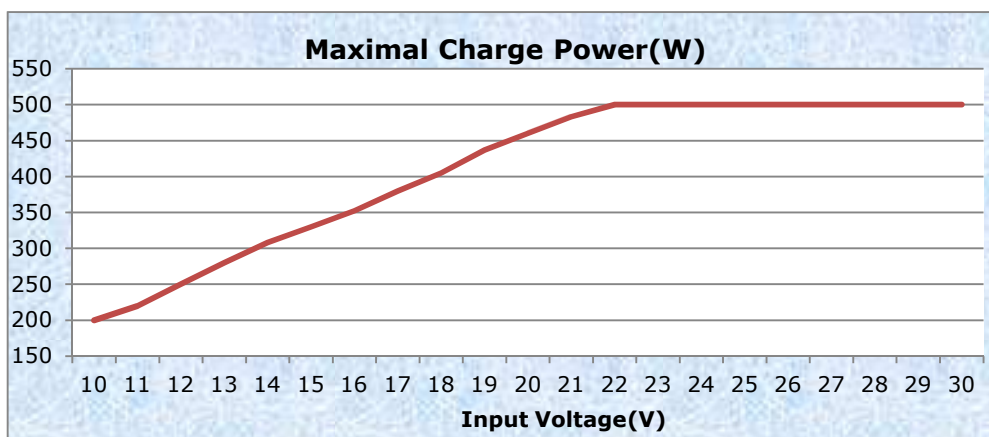

Typical Connection

The charger has two balance ports for 2S-6S and 7-12S separately, each balance port can connect to 2S-6S battery, if you have one battery pack under 6S such as 2S, 3S, 4S, 5S, you can connect the battery to balance port by adapter board, if you have two battery but total cell count is under 6S such as 3S+3S, 2S+2S, The connection is as below, two 3S packs will be charged as one 6S pack.

1. Connect two packs with heavy wire in series (as same as the Blue wire in following picture). Take two 3S battery as sample.

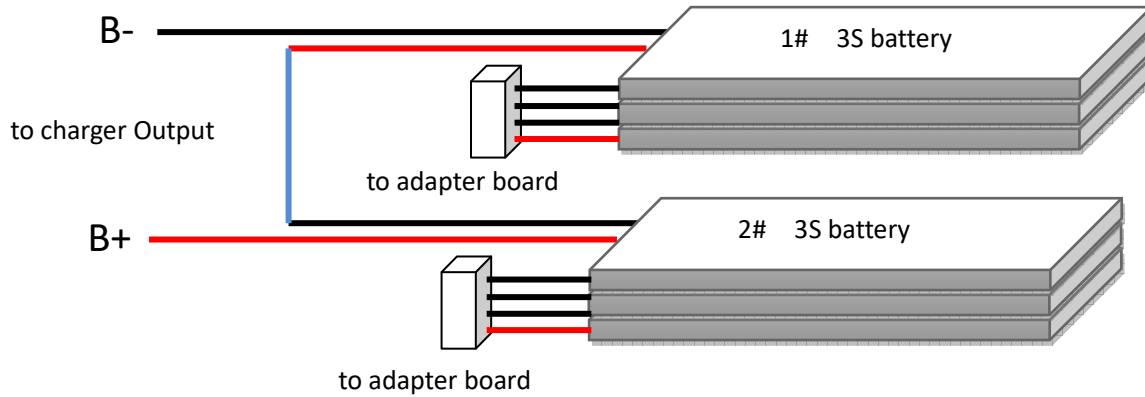

2. Plug 1# battery and 2# battery into adapter board, if plug into mistaken socket, the red LED will be on, please exchange the connector and plug it again.

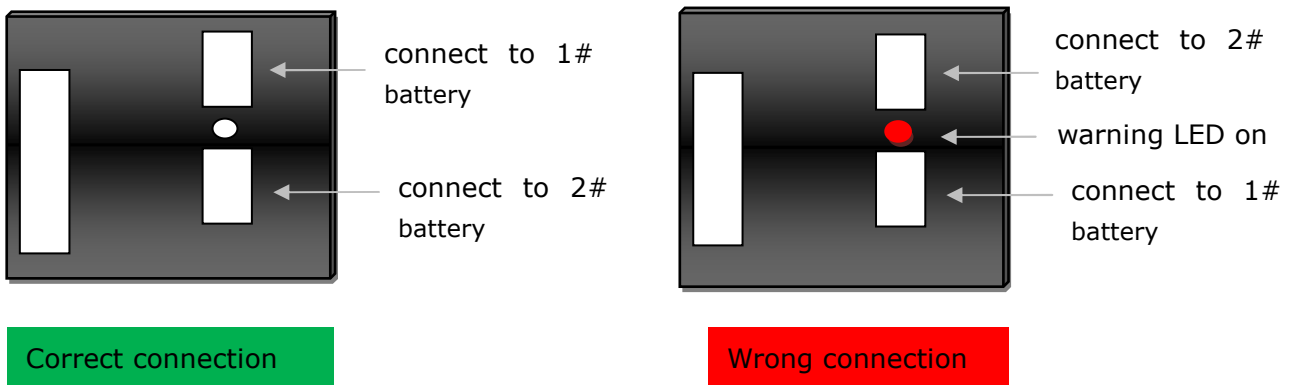

3. Connect total battery pack positive to charger output port B+, and connect battery negative to output port B-, finally connect adapter wire to charger balance port.

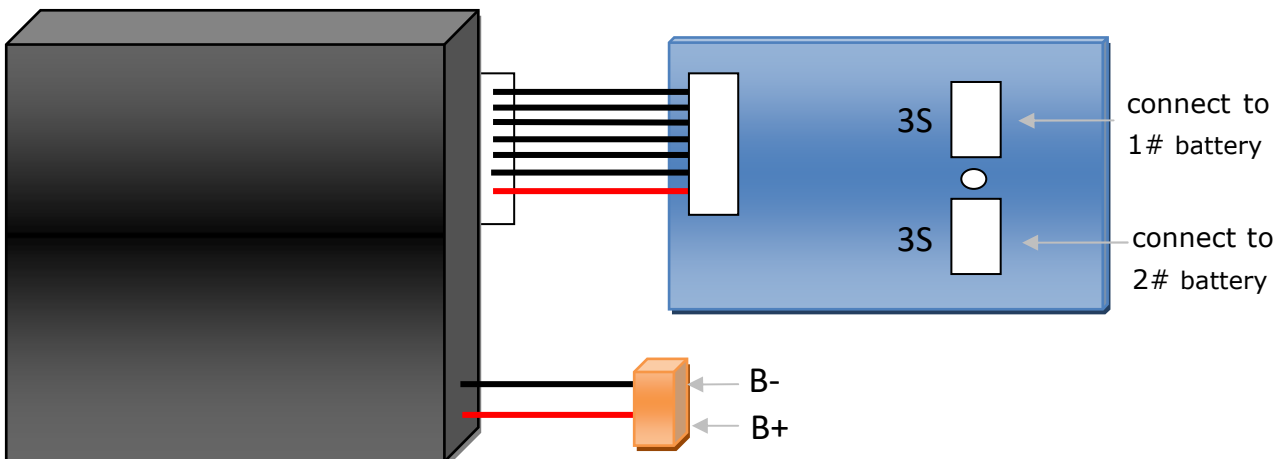

If you have two battery and total cell count is over 6S such as 5S+5S, 4S+4S, 6S+6S, 5S+3S, 3S+6S, and so on The connection is as below, two 5S packs will be charged as one 10S pack. For 6S+6S, if battery connector is XH type, you can connect the battery to balance port directly and need not adapter wire and adapter board.

1. Connect two or three packs with heavy wire (as same as the Blue wire in following picture). Take two 5S battery as sample.

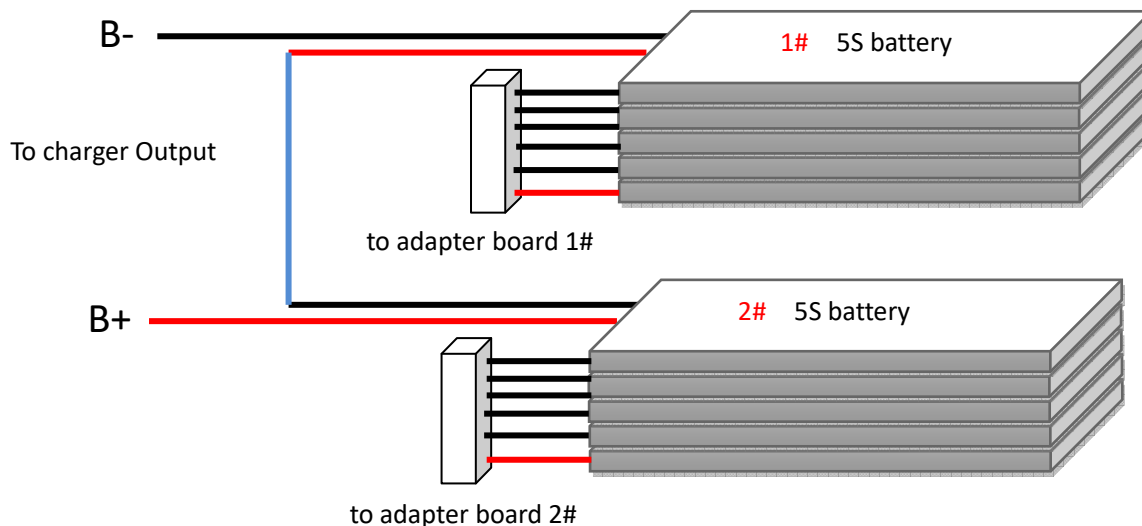



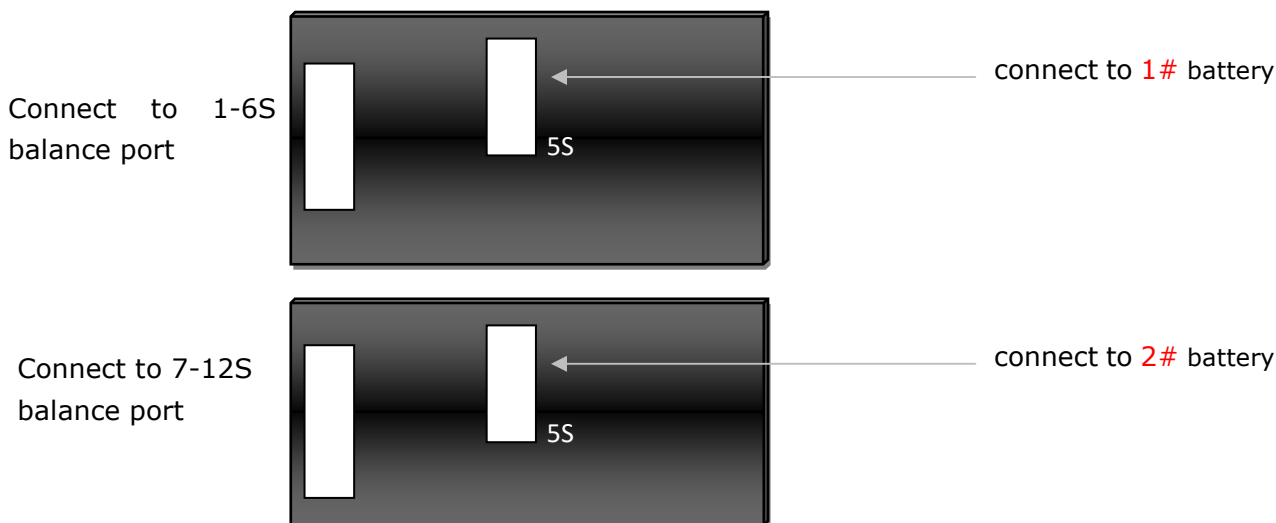

2. Plug 1# battery and 2# battery into two adapter board separately, .



3. Connect total battery pack positive to charger output port B+, and connect battery negative to output port B-, finally connect adapter wire to charger balance port.

Important thing is 1# battery must be connected to 1-6S balance port. Otherwise the charger will be damaged.

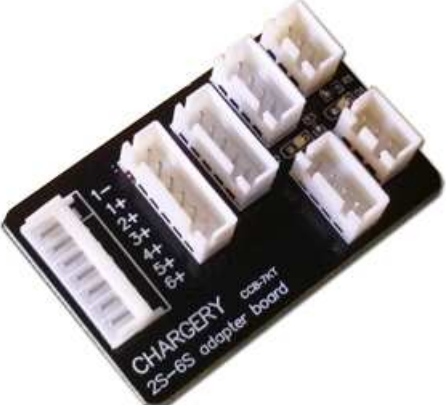
Accessory

<p>AC Input wire, 1500mm</p>	<p>DC Input wire, 600mm</p>
	
<p>Adapter wire: connect adapter board to balance port on C4012B</p>	<p>Adapter board:CCB-7KT for 6S battery</p>
	
<p>Temperature sensor</p>	<p>USB data line</p>
	

Related parts

The following device is related with 500W CHARGER

MODEL	DESCRIPTION	COMMENTS
5006B	1-6S Li-Ion/LiPo/LiFe battery, 1.3A balance current	
5008B	1-8S Li-Ion/LiPo/LiFe battery, 1.3A balance current	
50010B	1-10S Li-Ion/LiPo/LiFe battery, 1.3A balance current	
S600plus	600W power supply specially for 500W charger	DC5-26V, 25A 600W output





Version History

Version	Description
V1.16	First released
V1.20	Fix a bug pop up error when unbalanced at the end of charge
V1.21	Fix a bug pre-charge on LTO battery
V1.24	Fix a bug on balance charge mode

Warranty and Service

Chargery Power Co., Ltd. as manufacture of 1500W/500W CHARGER to be free of defects in material and workmanship. This warranty is effective for 12 months from date of purchase. If within the warranty period the customer is not satisfied with the products performance resulting from a manufacturing defect, the accessory will be replaced or repaired.

Your selling dealer is your first point of contact for warranty issues. Return postage costs are the responsibility of the user in all cases. Please submit copy of original receipt with the return.

Damage due to physical shock (dropping on the floor, etc.), inappropriate power supply (unstable output voltage and insufficient power, etc.), water, moisture, and humidity are specifically NOT covered by warranty.



Chargery Power Co., LTD.

Chuangye Road, Nanshan Shenzhen, 518054, China.

Tel: 86 (0)755 26436165, fax: 86 (0) 755 26412865

Email: jasonwang3a@163.com

Homepage: www.chargery.com

